

COLECCION
2009 - 2010



Iluminación



J. VILA
LAMPARAS, S.L.



EL SÍMBOLO DE CALIDAD STRASS®

THE STRASS® SYMBOL OF QUALITY

Cada una de las piezas de cristal tallado STRASS® (de 12mm de diámetro) llevan un símbolo de calidad grabado con láser en el cristal.



Las piezas de cristal STRASS® de las lámparas se distingue de cualquier otro producto de cristal por su brillo y su luminosidad. Sólo el auténtico cristal STRASS® llevan el certificado STRASS® en cada cristal como un símbolo de la calidad superior.



Each one of the STRASS® shaped glass pieces (of more than 12mm in diameter) carries a special certificate which guarantees the quality of the "Original". The Symbol of the quality is a laser impression on the crystal.



STRASS® crystal pieces on lamps stand out from any other product for their shine and brightness. Only authentic STRASS® crystal carried the STRASS® certificate on each piece of crystal as a symbol of superior quality.

índice

Modelo	Página	Modelo	Página
Lámparas y plafones		Sobremesas	
4772	16	5322	37
4773	15	5323	30
4774	14	5324	19
4775	12	5325	26
4776	13	5326	25
4777	8	5327	22
4778	7	5328	23
4779	9	5329	24
4780	10	5330	31
4781	6	5331	28
4782	5	5332	29
4783	2	5333	21
4784	1	5334	18
4785	3		
4787	11	Apliques	
4788	4	6317	38
4790	32	6326	13
4791	32	6327	11, 12
4792	33	6329	8
4793	30	6331	10
4794	19	6332	6
4795	20	6333	5
4796	21	6334	2
4797	26	6335	1
4798	27	6336	3
4799	25	6337	14
4800	4	6338	33
4801	36	6339	34
4802	37	6340	31
4803	35	6341	28
4804	22	6342	29
4805	23	6343	18
4806	24	6344	30
4807	35	6345	19
4808	34	6346	26
4809	31	6347	27
4810	28	6348	20
4811	29	6349	21
4812	18	6350	22
9324	17	6351	23
		6352	25
Sobremesas		6353	24
5313	12	6354	36
5314	6, 9	6355	38
5315	8	6356	7
5316	3, 5, 10	6357	9
5317	7		
5318	2, 20	Halógenos	
5319	13	HL-8	38
5320	11	HL-9	38
5321	1	HL-10	38

MODELO

4784

MEDIDAS

Ø cm	↑cm	●
55	50	6
68	60	8



MODELO

6335

MEDIDAS

Ø cm	↑cm	●
30	30	2

1



MODELO

5321

MEDIDAS

Ø cm	↑cm	●
25	50	1

1

MODELO
4783

MEDIDAS

Ø cm	↑cm	●
65	50	6
75	60	8



MODELO

6334

MEDIDAS

Ø cm	↑cm	●
36	32	2

2



MODELO

5318

MEDIDAS

Ø cm	↑cm	●
25	50	1



MODELO

4785

MEDIDAS

Ø cm	↑cm	●
60	54	6
70	60	8



MODELO

6336

MEDIDAS

Ø cm	↑cm	●
34	30	2



MODELO

5316

MEDIDAS

Ø cm	↑cm	●
25	50	1

MODELO

4788

MEDIDAS

Ø cm	↑cm	●
35	45	4
46	46	6
55	55	8



MODELO

4800

MEDIDAS

Ø cm	↑cm	●
30	50	15
45	70	28





MODELO

4782

MEDIDAS

Ø cm	↑cm	●
58	40	6
68	43	8
80	45	10

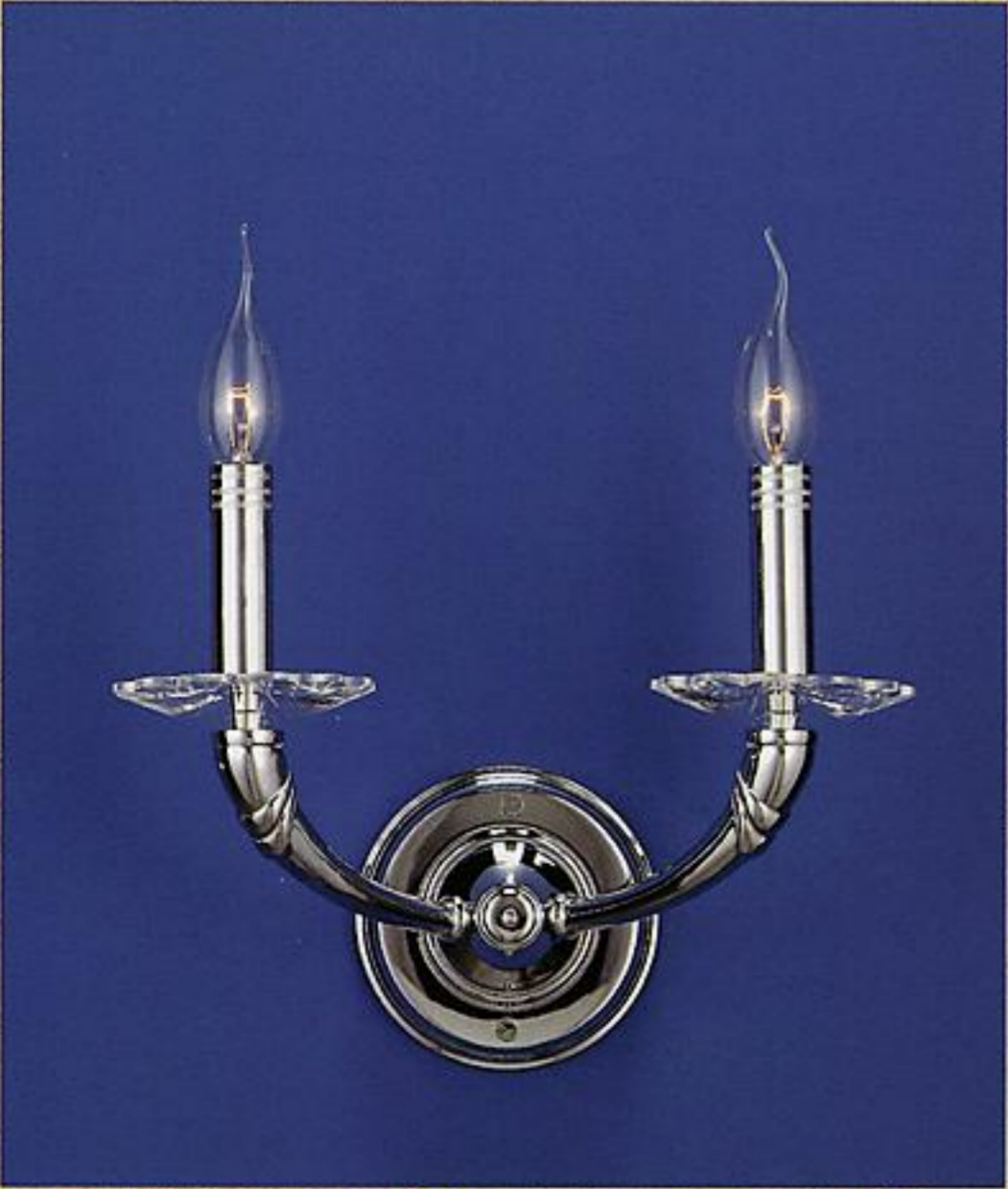

MODELO

6333

MEDIDAS

Ø cm	↑cm	●
31	23	2
13	23	1



MODELO

5316

MEDIDAS

Ø cm	↑cm	●
25	50	1

MODELO

4781

MEDIDAS

Ø cm	↑cm	●
58	40	6
68	42	8
75	45	10



MODELO

6332

MEDIDAS

Ø cm	↑cm	●
31	23	2
13	23	1



MODELO

5314

MEDIDAS

Ø cm	↑cm	●
25	55	1



MODELO
4778

MEDIDAS

Ø cm	↑cm	●
59	43	6
68	45	8
78	45	10

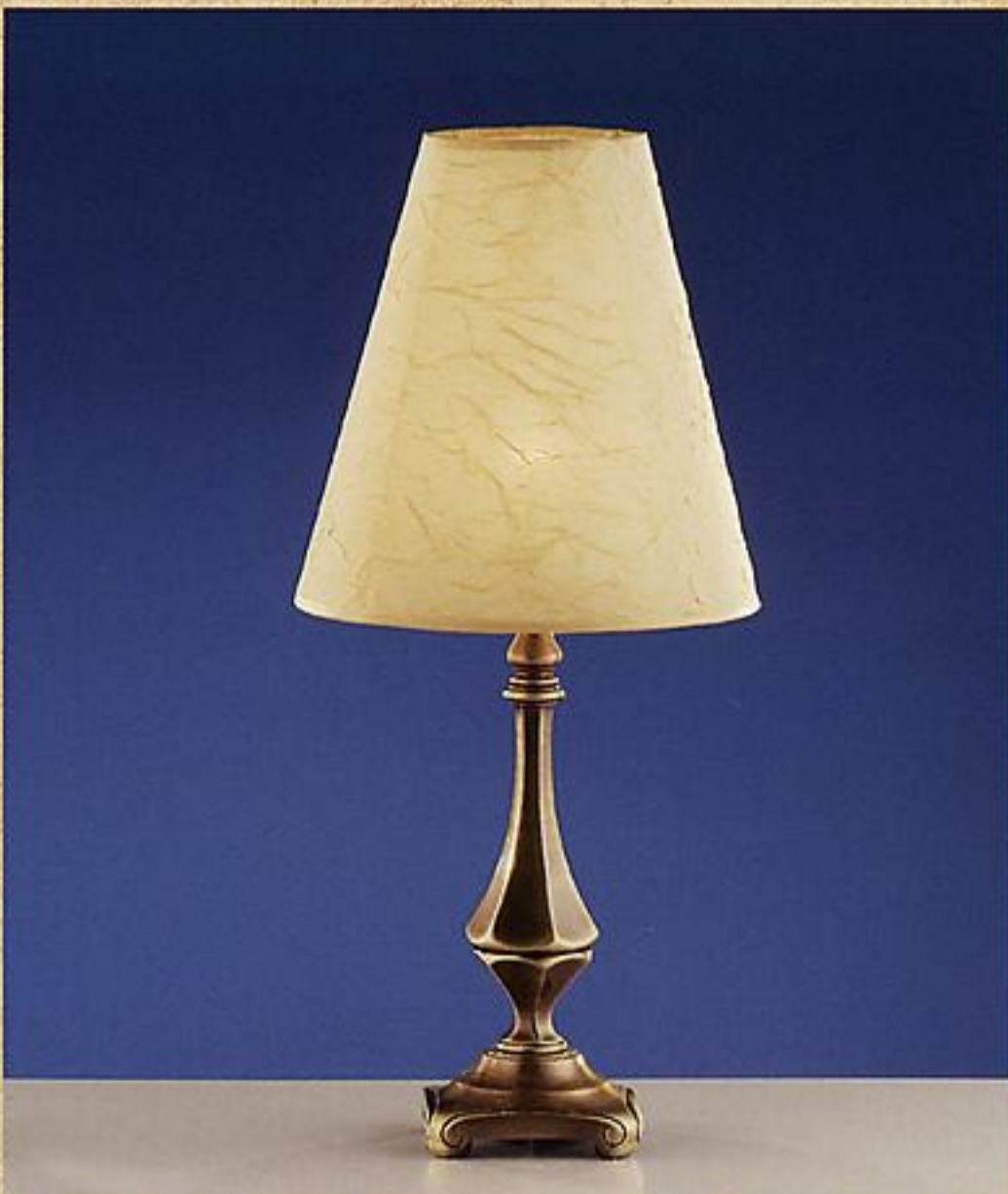

MODELO
5317

MEDIDAS

Ø cm	↑cm	●
25	55	1



MODELO
6356

MEDIDAS

Ø cm	↑cm	●
13	20	1
38	20	2

MODELO

4777

MEDIDAS

Ø cm	↑cm	●
58	42	6
68	45	8
78	45	10

**MODELO**

5315

MEDIDAS

Ø cm	↑cm	●
25	55	1

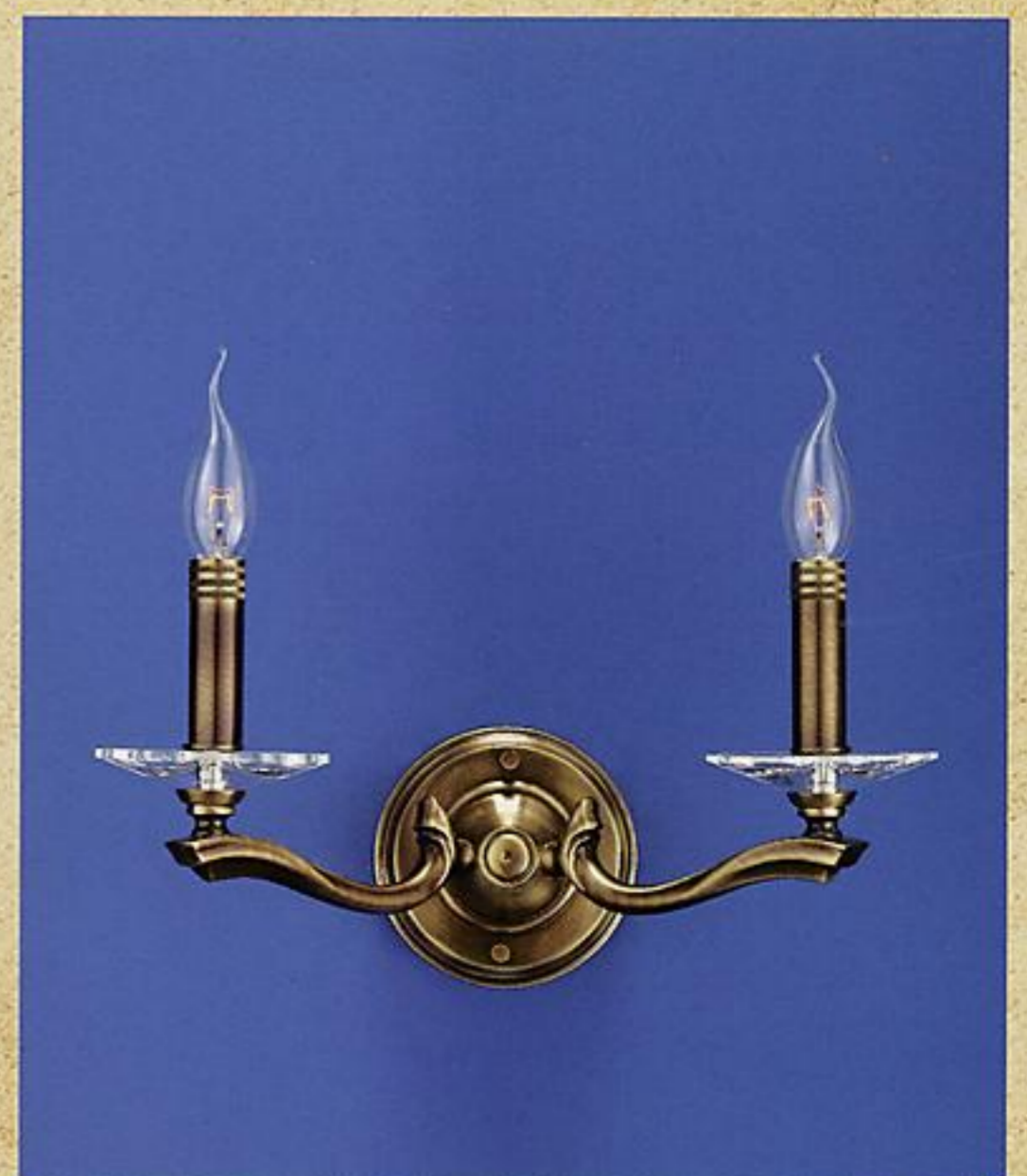
**MODELO**

6329

MEDIDAS

Ø cm	↑cm	●
38	20	2
13	20	1

MODELO

4779

MEDIDAS

Ø cm	↑cm	●
60	40	6
68	42	8
78	45	10



MODELO

6357

MEDIDAS

Ø cm	↑cm	●
13	20	1
33	20	2



MODELO

5314

MEDIDAS

Ø cm	↑cm	●
25	55	1

MODELO

4780

MEDIDAS

Ø cm	↑cm	●
60	40	6
68	42	8
78	45	10



MODELO

5316

MEDIDAS

Ø cm	↑cm	●
25	50	1

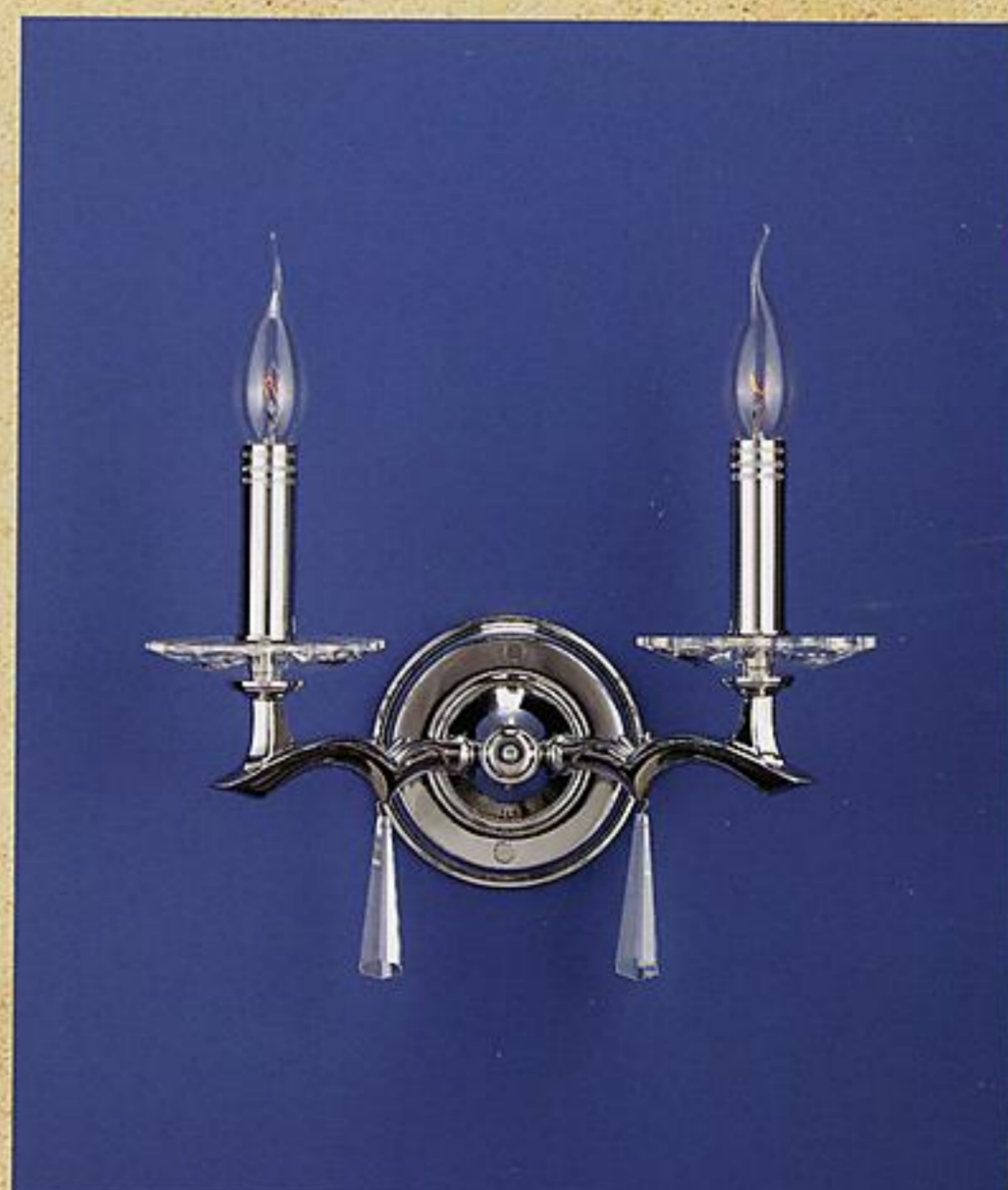

MODELO

6331

MEDIDAS

Ø cm	↑cm	●
33	18	2
13	18	1

MODELO

4787

MEDIDAS

Ø cm	↑cm	●
58	40	6
69	43	8
82	47	10

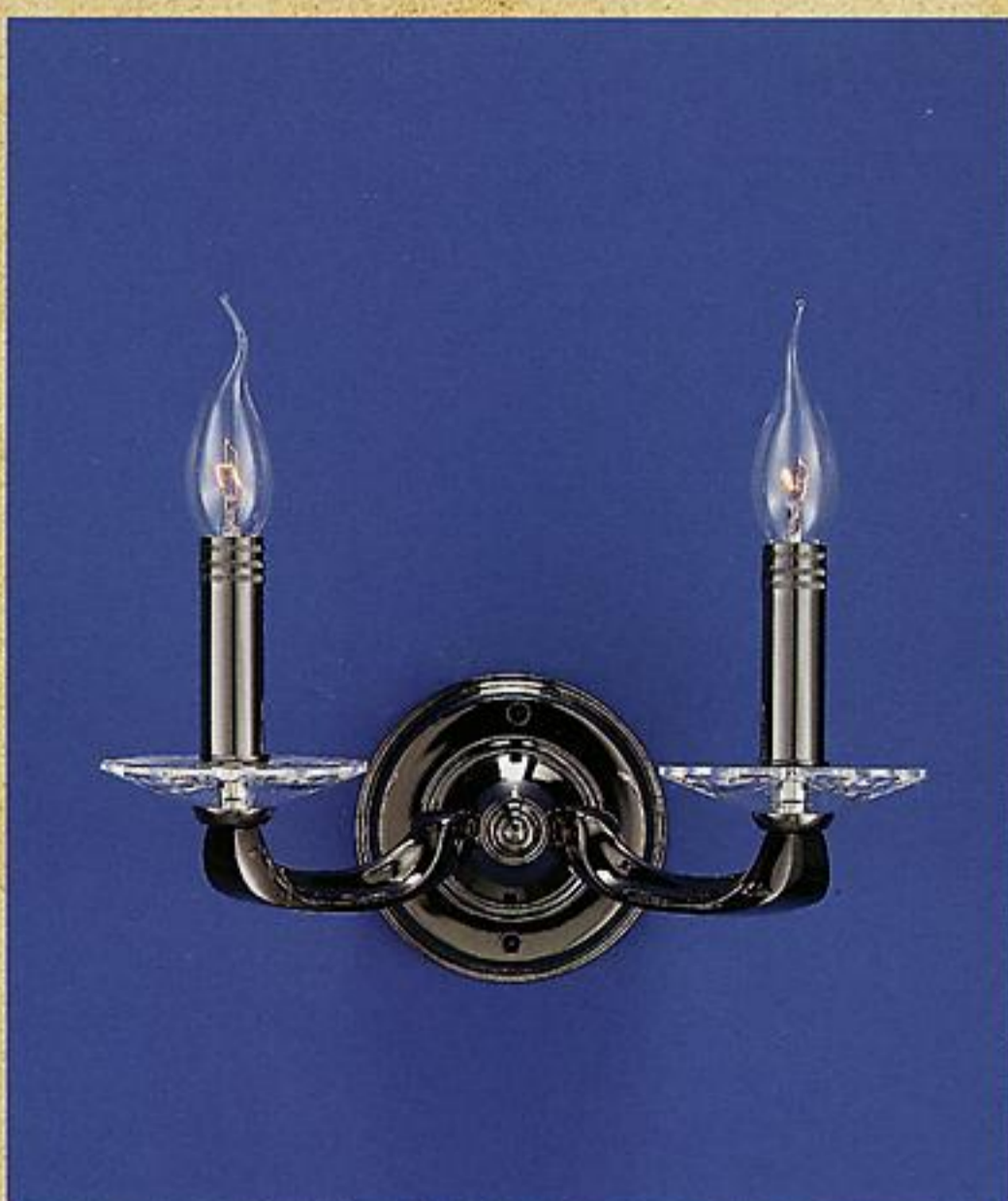

MODELO

6327

MEDIDAS

Ø cm	↑cm	●
33	18	2
13	18	1

MODELO

5320

MEDIDAS

Ø cm	↑cm	●
25	50	1



MODELO

4775

MEDIDAS

Ø cm	↑cm	●
58	42	6
69	42	8
82	47	10



MODELO

5313

MEDIDAS

Ø cm	↑cm	●
25	55	1

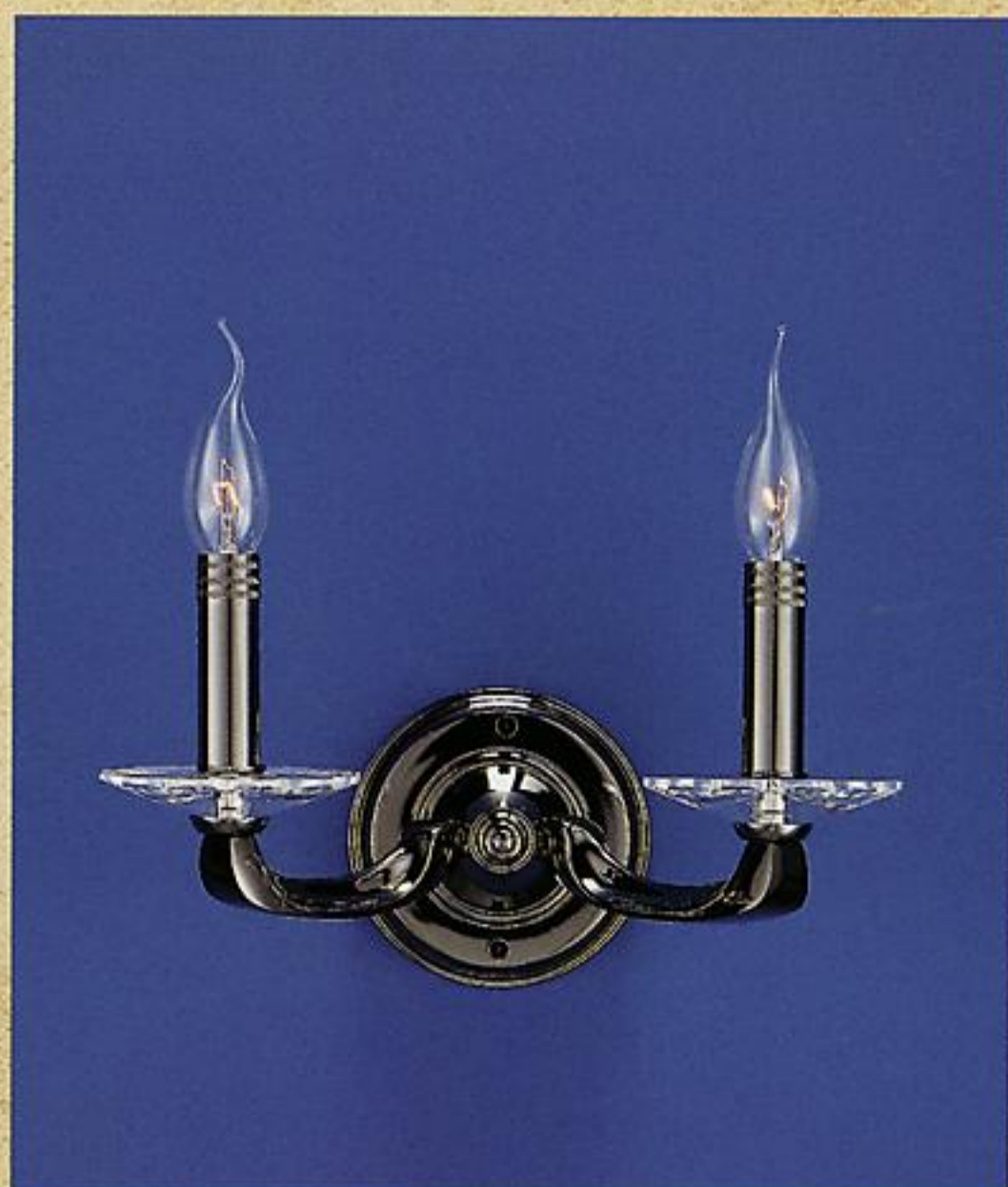

MODELO

6327

MEDIDAS

Ø cm	↑cm	●
33	18	2
13	18	1

MODELO

4776

MEDIDAS

Ø cm	↑cm	●
58	42	6
69	42	8
82	47	10



MODELO

5319

MEDIDAS

Ø cm	↑cm	●
25	50	1

MODELO

6326

MEDIDAS

Ø cm	↑cm	●
32	18	2
13	18	1

MODELO

4774

MEDIDAS

Ø cm	↑cm	●
110	90	12
90	80	10
75	70	8

**MODELO**

6337

MEDIDAS

Ø cm	↑cm	●
48	65	3+2

**MODELO**

4773

MEDIDAS

Ø cm	↑cm	●
155	170	20+10
100	140	12+ 6



MODELO

4772

MEDIDAS

Ø cm	↑cm	●
155	210	20+10+10
100	150	12+ 6 + 6

**MODELO**

9324

MEDIDAS

\varnothing cm	↑cm	●
35	65	4
45	80	6

MODELO

4812

MEDIDAS

Ø cm	↑cm	●
55	40	3
60	40	5
70	40	6

**MODELO**

5334

MEDIDAS

Ø cm	↑cm	●
11	40	1

**MODELO**

6343

MEDIDAS

Ø cm	↑cm	●
13	23	1
30	23	2

MODELO

4794

MEDIDAS

Ø cm	↑cm	●
60	40	6
80	45	8



MODELO

6345

MEDIDAS

Ø cm	↑cm	●
13	26	1
38	26	2



MODELO

5324

MEDIDAS

Ø cm	↑cm	●
30	50	1

MODELO

4795

MEDIDAS

Ø cm	↑cm	●
58	46	6
69	50	8

**MODELO**

5318

MEDIDAS

Ø cm	↑cm	●
25	50	1

**MODELO**

6348

MEDIDAS

Ø cm	↑cm	●
13	20	1
33	20	2

MODELO

4796

MEDIDAS

Ø cm	↑cm	●
58	46	6
69	50	8

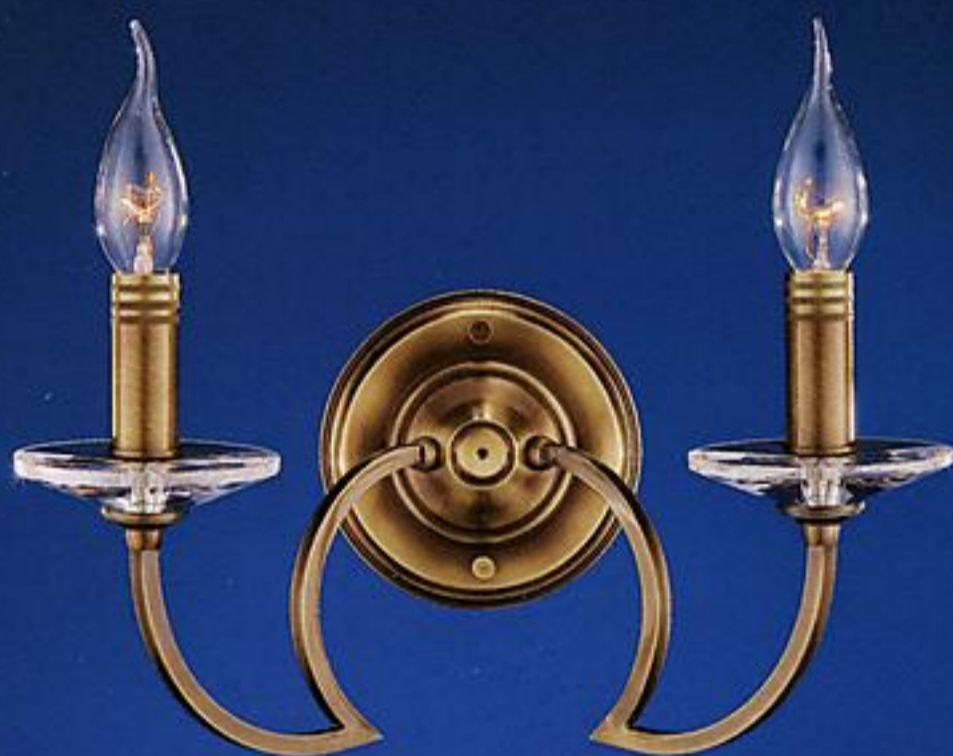

MODELO

6349

MEDIDAS

Ø cm	↑cm	●
13	20	1
35	20	2



MODELO

5333

MEDIDAS

Ø cm	↑cm	●
25	55	1

MODELO

4804

MEDIDAS

Ø cm	↑cm	●
57	40	6
70	45	8

**MODELO**

5327

MEDIDAS

Ø cm	↑cm	●
25	55	1

**MODELO**

6350

MEDIDAS

Ø cm	↑cm	●
13	16	1
37	16	2

MODELO

4805

MEDIDAS

Ø cm	↑cm	●
57	40	6
70	45	8



MODELO

6351

MEDIDAS

Ø cm	↑cm	●
13	26	1
37	26	2



MODELO

5328

MEDIDAS

Ø cm	↑cm	●
25	55	1

MODELO

4806

MEDIDAS

Ø cm	↑cm	●
57	47	6
70	50	8

**MODELO**

5329

MEDIDAS

Ø cm	↑cm	●
25	55	1

**MODELO**

6353

MEDIDAS

Ø cm	↑cm	●
13	28	1
35	28	2



MODELO

4799

MEDIDAS

Ø cm	↑cm	●
57	47	6
70	50	8



MODELO

6352

MEDIDAS

Ø cm	↑cm	●
13	30	1
30	30	2



MODELO

5326

MEDIDAS

Ø cm	↑cm	●
25	55	1

MODELO

4797

MEDIDAS

Ø cm	↑cm	●
60	53	5
62	60	6
70	60	8

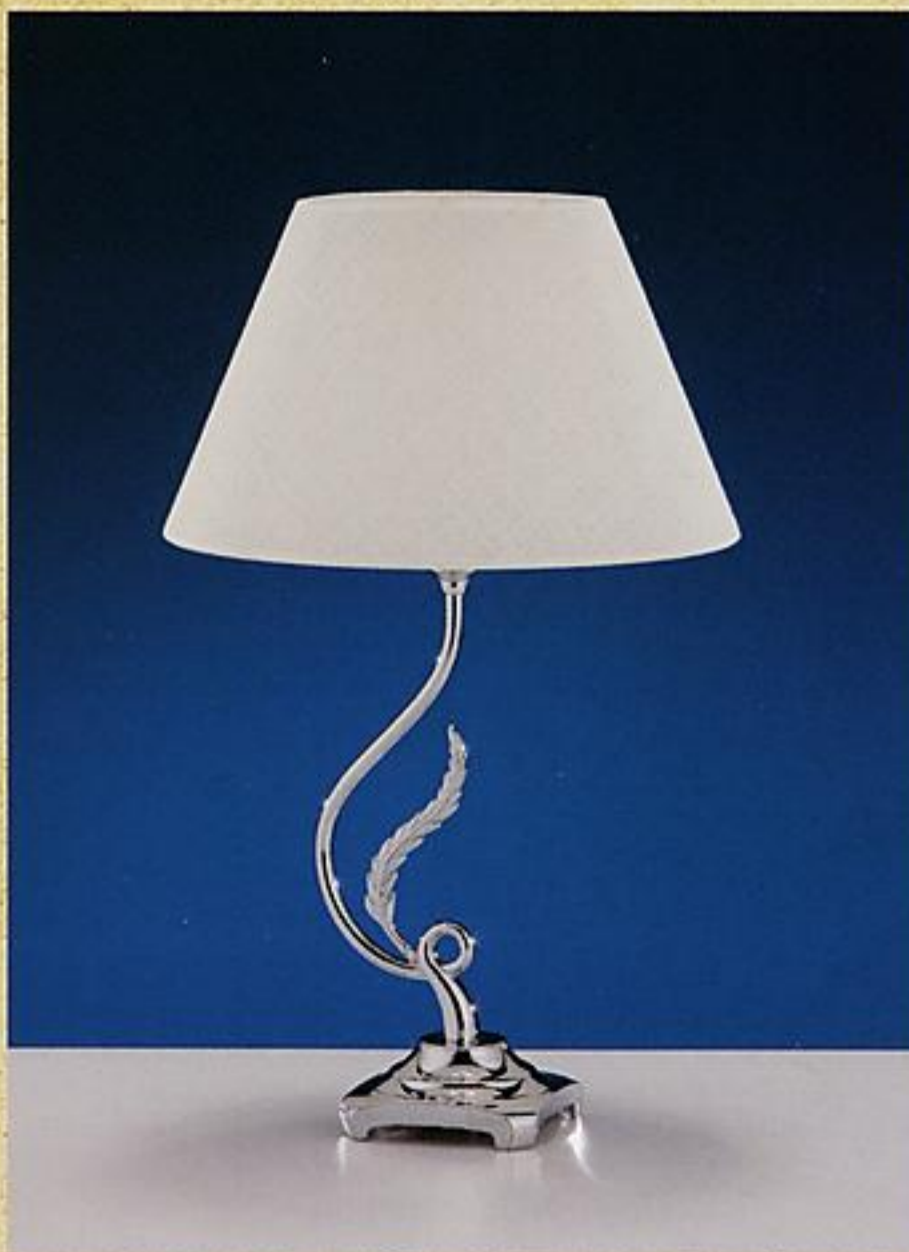
**MODELO**

5325

MEDIDAS

Ø cm	↑cm	●
30	50	1

**MODELO**

6346

MEDIDAS

Ø cm	↑cm	●
13	17	1
37	18	2

MODELO

4798

MEDIDAS

Ø cm	↑cm	●
68	53	5
72	60	6
82	67	8

**MODELO**

6347

MEDIDAS

Ø cm	↑cm	●
18	28	1
47	28	2

MODELO

4810

MEDIDAS

Ø cm	↑cm	●
55	40	5
56	40	6
67	45	8

**MODELO**

5331

MEDIDAS

Ø cm	↑cm	●
25	55	1

**MODELO**

6341

MEDIDAS

Ø cm	↑cm	●
13	30	1
30	30	2



MODELO

4811

MEDIDAS

Ø cm	↑cm	●
55	40	5
56	40	6
67	45	8



MODELO

6342

MEDIDAS

Ø cm	↑cm	●
13	31	1
35	31	2



MODELO

5332

MEDIDAS

Ø cm	↑cm	●
25	55	1

MODELO

4793

MEDIDAS

Ø cm	↑cm	●
60	40	6
70	45	8

**MODELO**

5323

MEDIDAS

Ø cm	↑cm	●
30	50	1

**MODELO**

6344

MEDIDAS

Ø cm	↑cm	●
13	33	1
38	33	2

MODELO

4809

MEDIDAS

Ø cm	↑cm	●
54	50	6+3
70	55	8+4
83	60	10+5



MODELO

6340

MEDIDAS

Ø cm	↑cm	●
28	30	2+1



MODELO

5330

MEDIDAS

Ø cm	↑cm	●
25	55	1

MODELO

4790

MEDIDAS

Ø cm	↑cm	●
50	60	8
60	65	10
80	80	16

**MODELO**

4791

MEDIDAS

Ø cm	↑cm	●
30	25	3
40	27	4
50	30	6
60	33	8
80	33	12





MODELO

4792

MEDIDAS

Ø cm	↓cm	●
80	45	12
100	50	18



MODELO

6338

MEDIDAS

Ø cm	↓cm	●
29	20	2

MODELO

4808

MEDIDAS

Ø cm	↑cm	●
33	35	3
40	44	4
47	48	5
55	55	6

**MODELO**

6339

MEDIDAS

Ø cm	↑cm	●
30	20	2



MODELO

4807

MEDIDAS

Ø cm	↑cm	●
33	26	3
40	30	4
47	34	5
55	38	6



MODELO

4803

MEDIDAS

Ø cm	↑cm	●
26	16	2
31	18	3
36	20	4
41	22	5

MODELO

4801

MEDIDAS

Ø cm	↓cm	●
30	50	10
37	60	18
45	70	28

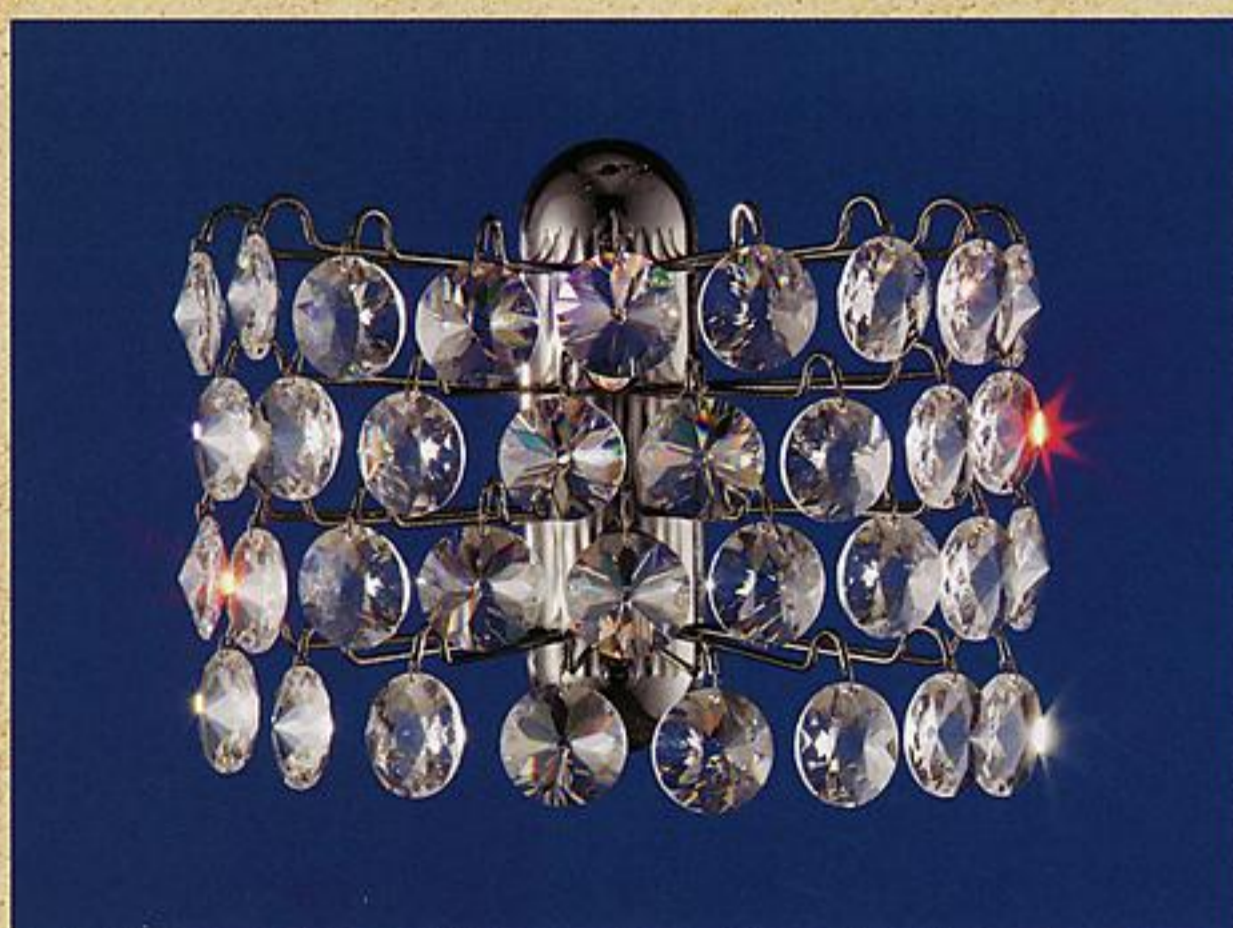
**MODELO**

6354

MEDIDAS

Ø cm	↓cm	●
28	20	2



MODELO

4802

MEDIDAS

Ø cm	↑cm	●
25	20	4
30	25	6
37	30	9
45	35	12

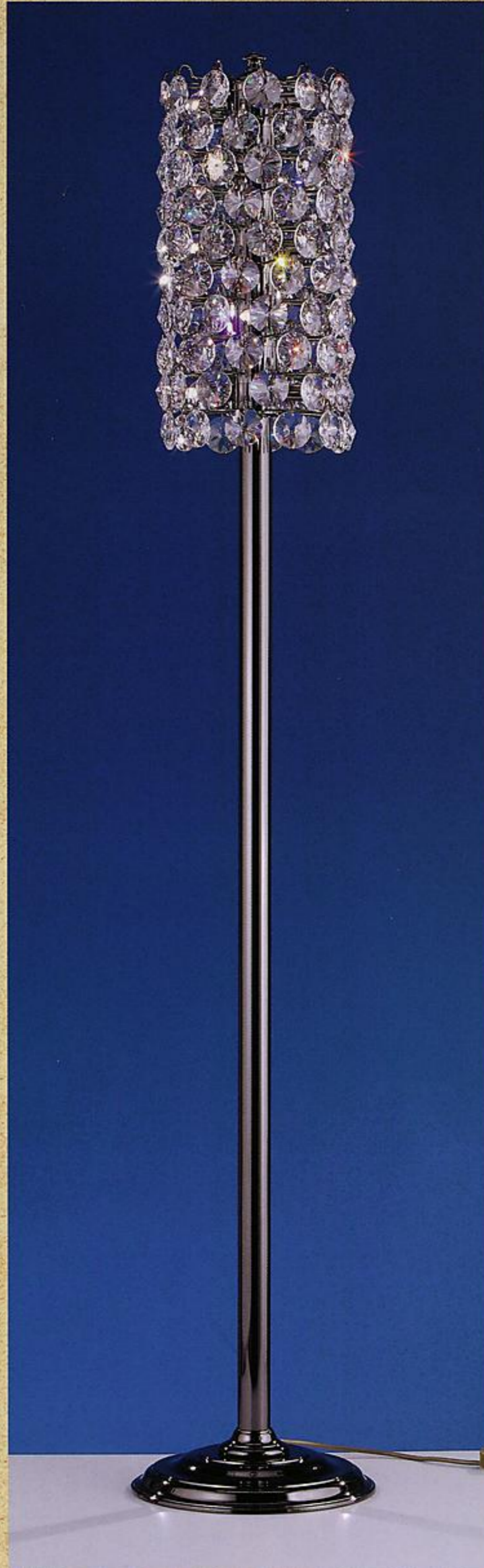

MODELO

5322

MEDIDAS

Ø cm	↑cm	●
25	175	10
30	175	10

MODELO

6355

MEDIDAS

↔ cm	↑ cm	↗ cm	●
31	11	12	5 LEDS



MODELO

6317

MEDIDAS

↔ cm	↑ cm	↗ cm	●
20	20	18	1
31	20	18	2
60	20	18	4

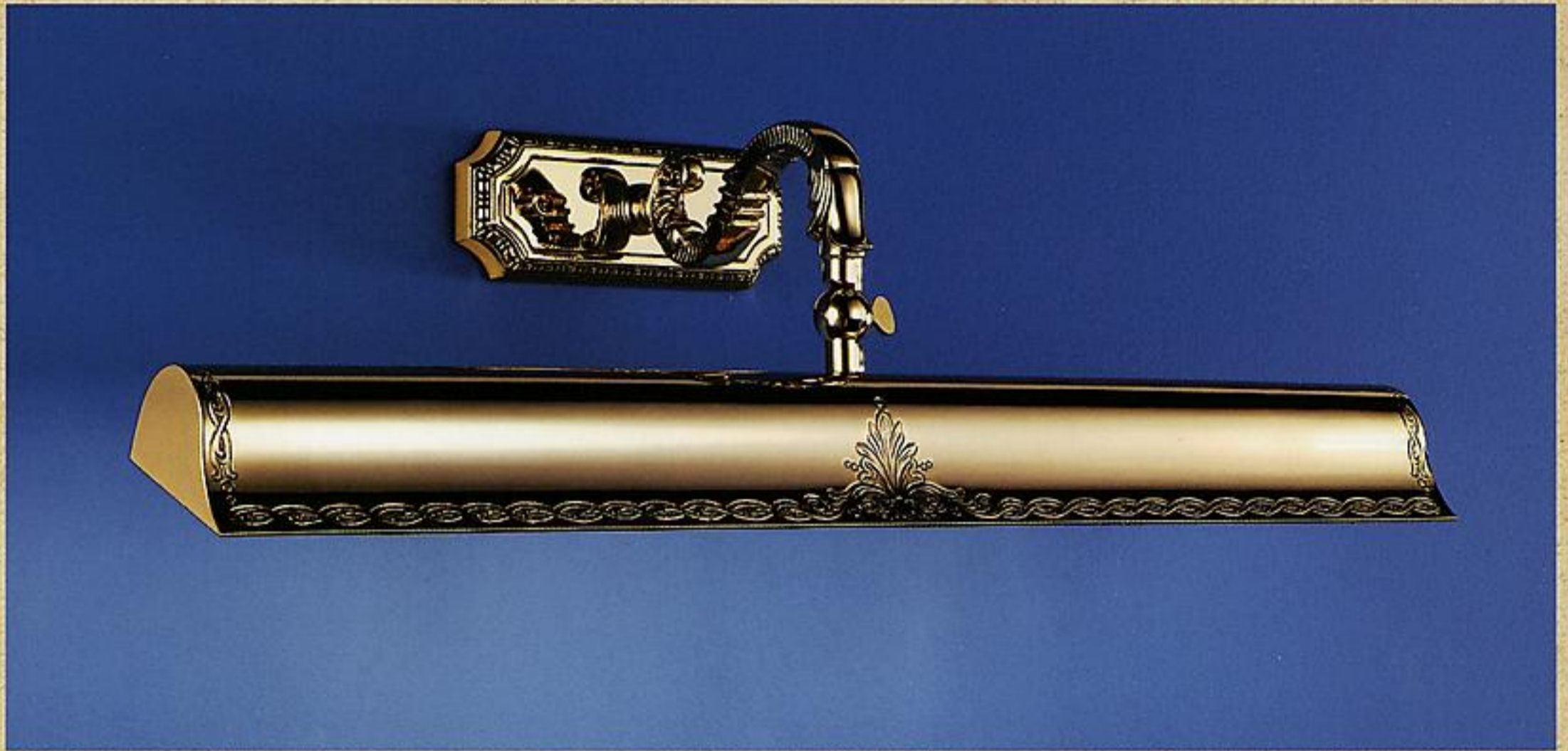

MODELO

HL-9

MEDIDAS

mm.

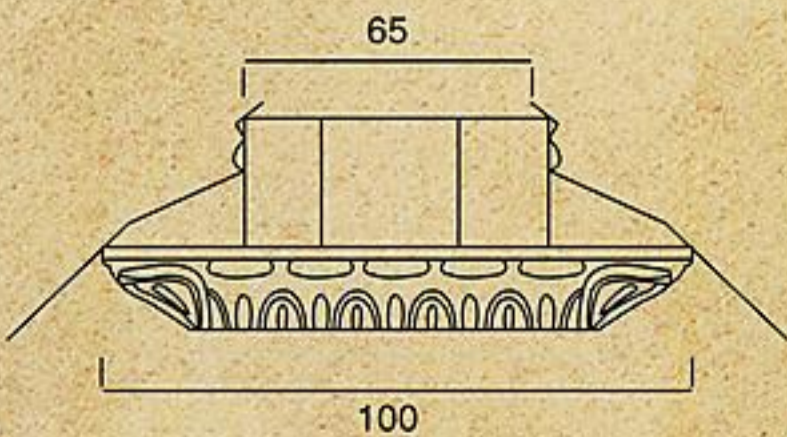

MODELO

HL-8

MEDIDAS

mm.

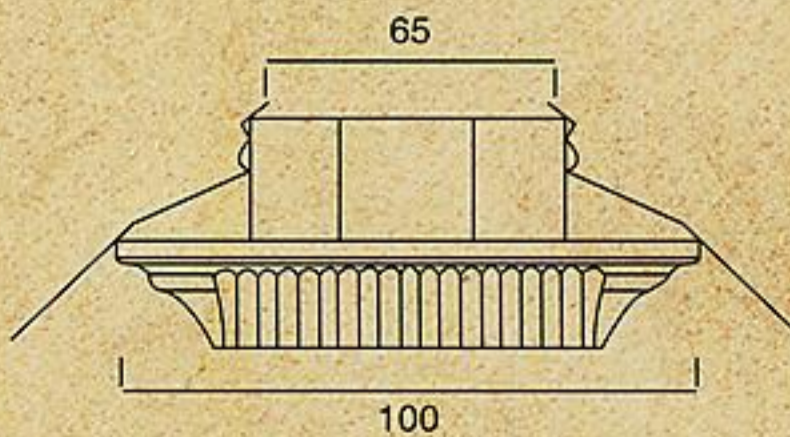

MODELO

HL-10

MEDIDAS

mm.

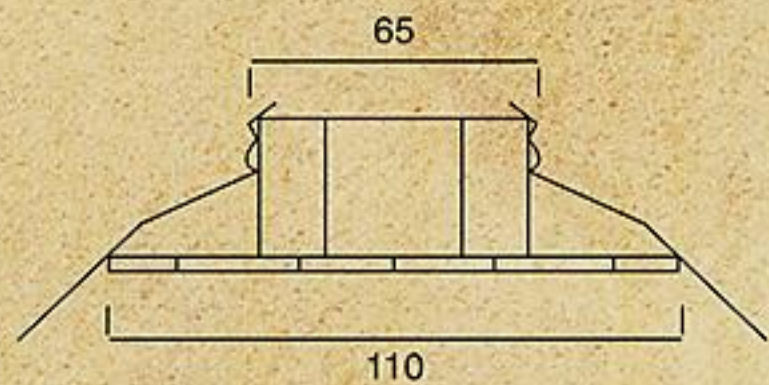

Notas de interes general

Símbolos utilizados

∅ Diámetro o ancho, medidas en centímetros.

↑↓ Altura del aparato sin florón ni cadena, en centímetros.

● Número de bombillas.

· Todos los aparatos se sirven sin bombillas, recomendamos que lo mismo las de E27 que las de vela E14 sean claras transparentes de 40 o 60 W.

Algunas especificaciones sobre los materiales y otros asuntos relacionados en la fabricación de nuestros aparatos.

- Las principales materias primas son de bronce y metal compuesto del 65% de cobre y 35% de zinc.
- Todos los aparatos son fabricados a mano de forma artesanal por personal altamente cualificado.
- Los acabados son pulidos a mano y bañados electrolíticamente en oro de 24 quilates, a continuación se aplican las patinas y se le da una película de laca que se seca a 190° C.
- Nosotros cuidamos hasta el más mínimo detalle de hecho que el resultado final es tener el convencimiento de haber realizado el trabajo con plena satisfacción.
- Las representaciones de cada serie de este catálogo han sido ensayadas según las normas de la serie EN60598 por el prestigioso laboratorio Sering-2000. También disponemos del SASO para las exportaciones a Arabia Saudi.
- Las partes eléctricas son las homologadas según el país de destino.
- El fabricante se reserva el derecho a introducir cambios o mejoras en los artículos exhibidos en este catálogo.
- Las medidas indicadas son aproximadas.
- Para cualquier información complementaria contacte con nosotros.

Notes of general interest

Symbols used

∅ Diameter or width, measures in centimetres.

↑↓ Height of the unit without canopy or chain, in centimetres.

● Number of bulbs.

· Units do not include bulds. We recommend that both the E27 and the E14 candle types be 40 or 60 W and transparent.

Some specifications about materials and other matters relating to the manufacture of our units.

- The main raw materials used are bronze and metal compound containing 65% copper and 35% zinc.
- All units are hand crafted by highly qualified personnel.
- The finishes are hand buffed and given an electrolytically bath in 24 carat gold. The patinas are then applied, given a lacquer coating, and dried at 190° C.
- We take care of every last detail to be fully confident that the workmanship is completely satisfactory.
- The various models of each line in this catalogue have been tested in accordance with regulation EN60598 by the prestigious Laboratory Sering-2000. We also possess the SASO for export to Saudi Arabia.
- The electrical components meet the standards required by each country exported to.
- The manufacturer reserves the right to introduce changes and improvements to products displayed in this catalogue.
- Measures shown are approximate.
- For any further information, please contact us.



C/ Sant Francesc,55-61 - Telefono +34-96 120 37 19 - Fax +34-96 120 32 51
Poligono Industrial San Francisco - 46469 BENIPARRELL (VALENCIA) Spain
E-mail: jvilalamp@jvilalamp.com / vilalamp@jvilalamp.com
Web : www.jvilalamp.com